

QUADGUARD® II

The New Standard in Crash Cushions



OVERVIEW

The QuadGuard family has evolved again! Using the existing framework of the QuadGuard, the QuadGuard II provides TL-2 and TL-3 protection using less length. The TL-2 QuadGuard II is 25% shorter than the original QuadGuard measuring less than 3m (10'). The TL-3 model is also nearly a meter, 3 feet, shorter than its predecessor.

The only modifications are the addition of the revolutionary Steel Nose, and the monorail Guide Stabilizers. The remaining components are identical to the existing NCHRP 350 systems that have been installed globally since the mid 1990's.

The QuadGuard II will telescope rearward on head-on impacts by both the light car and the high center-of-gravity pickup truck at speeds up to 100 km/h (62 mph) and safely redirect errant vehicles on impact up to 20 angles into the side of the unit without gating.

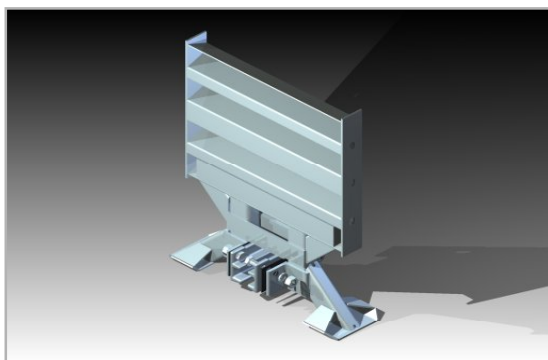
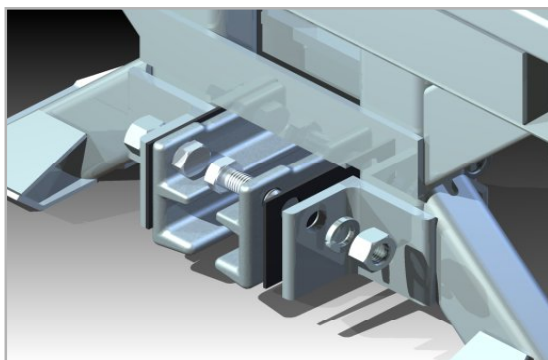

POST IMPACT DEBRIS

The design of the QuadGuard II does an excellent job of minimizing debris affecting other vehicles in the roadway.

FEATURES AND BENEFITS

- More is LESS!
- QuadGuard II has up to 25% less footprint reducing installation cost
- Steel Nose provides excellent visibility
- Majority of system is identical to QuadGuard- reduced inventory requirements
- Shorter Systems are less likely to be impacted
- Offers hazard protection from 40 km/h (25mph) to 115 km/h to (70mph)



**ENERGY ABSORPTION
SYSTEMS, INC.**

SAVING LIVES BY DESIGN®

www.energyabsorption.com

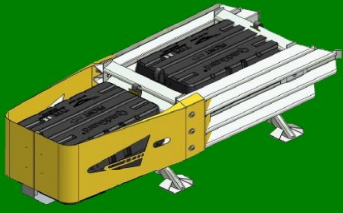

SPECIFICATIONS

Minimum Width at Backup	610 mm	(2')
Maximum Width at Backup	2.3 m	(8')
TL-2 Effective Length	2.6 m	(8'8")
TL-3 Effective Length	5.4 m	(8'8")

- 1 ENGINEERED STEEL NOSE
- 2 MONORAIL
- 3 STEEL BACKUP
- 4 FENDER PANEL

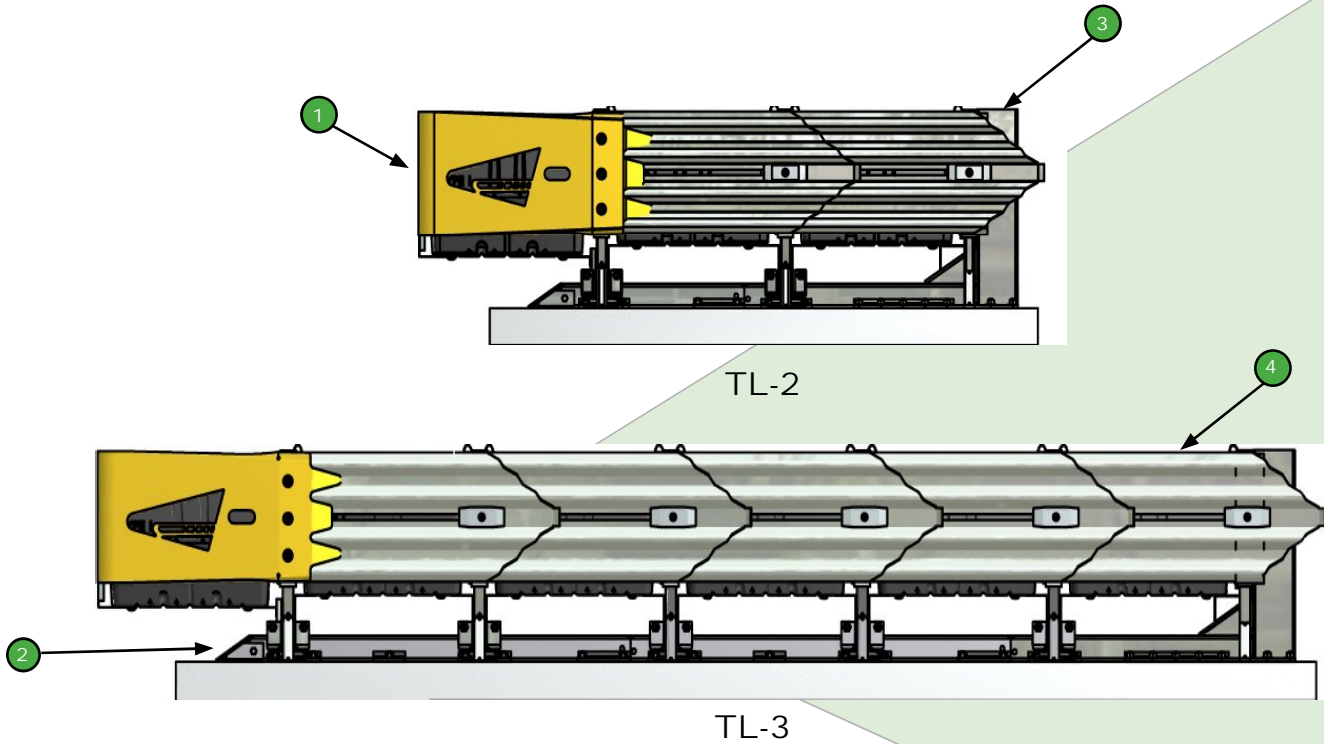

DISTRIBUTED BY: